

saheco

Junio 2011

SF-A84D

Poligono Industrial Foradada - 08580 - Sant Quirze de Besora (Barcelona)
 Telf. 34-93.852.92.23, Fax 34-93.852.91.59
 Export. Telf. 34-93.852.96.15, Fax 34-93.852.91.76
 e-mail: saheco@saheco.com
 web: www.saheco.com

**GRUPO
TORREMAT**

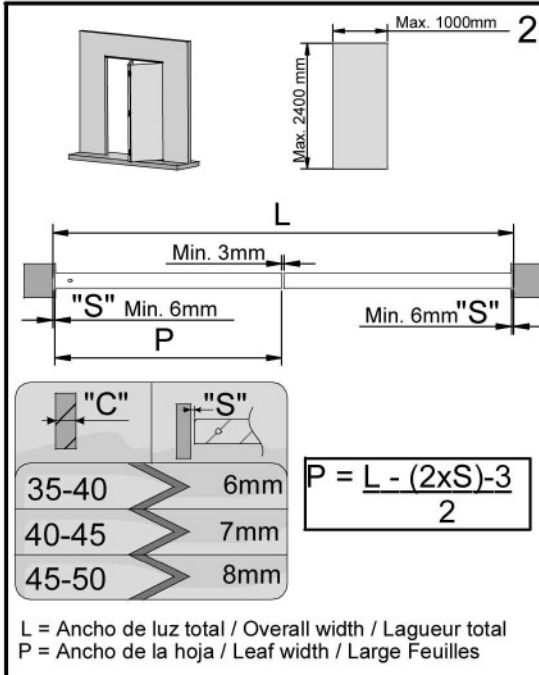
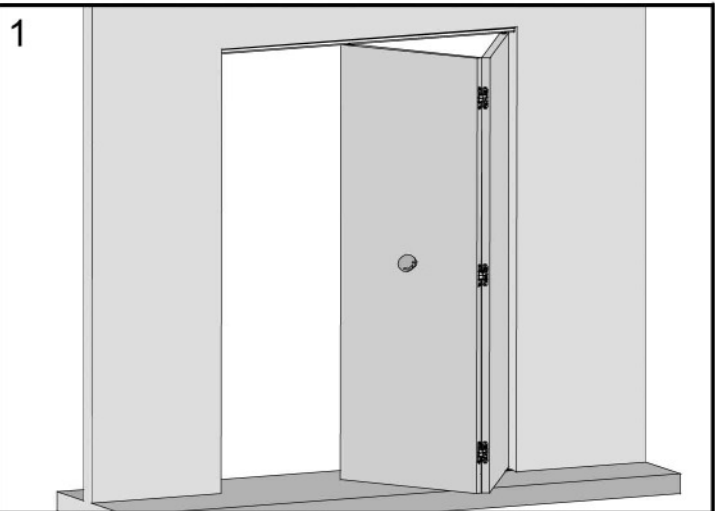

z		1	t		1
y		1	s		1
x		1	r		1
w		1	p		2
v	 Din 7505 3,5x40	6	n	 Din 7505 4,5x50	2
u		2	m		1
vt		2			

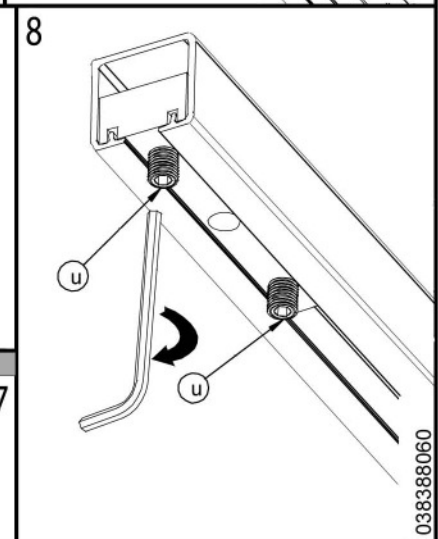
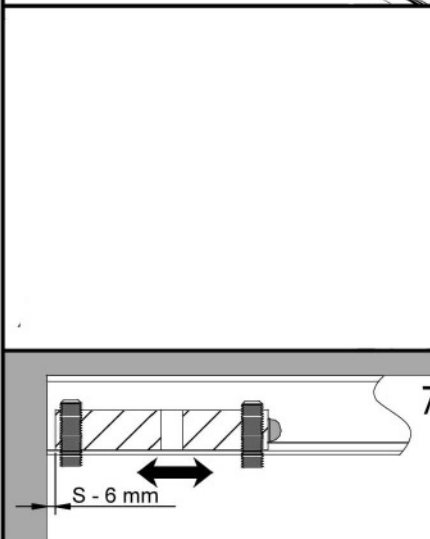
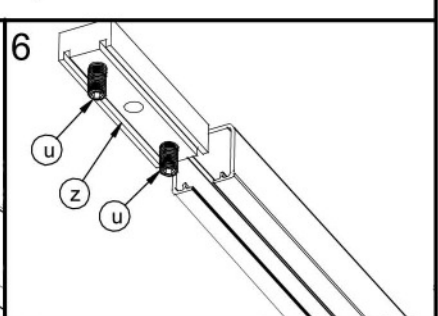
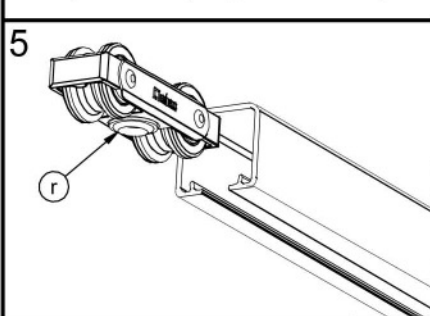
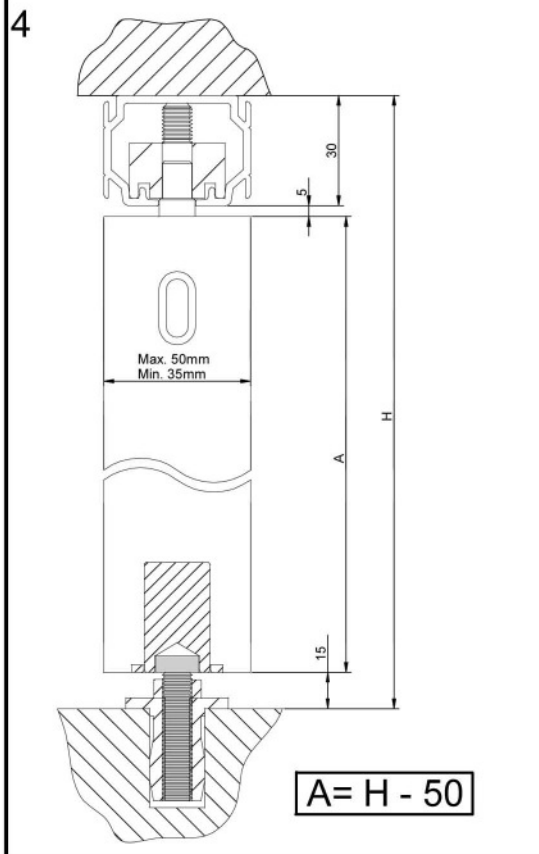

038388060

Made in Spain

Swing door mechanisation

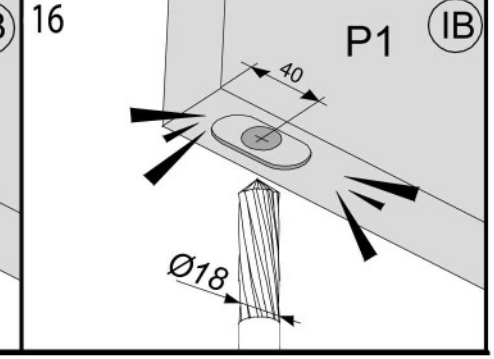
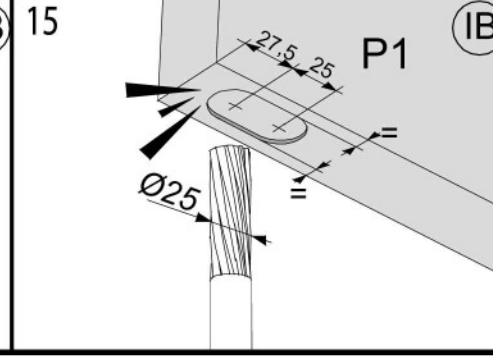
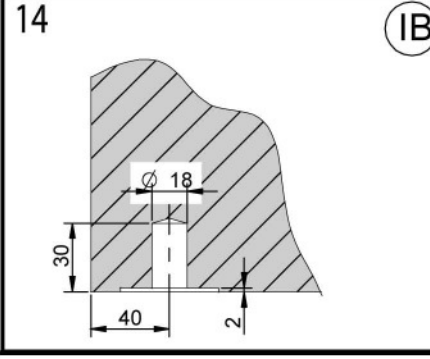
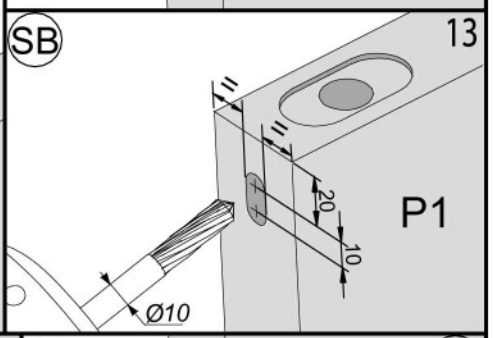
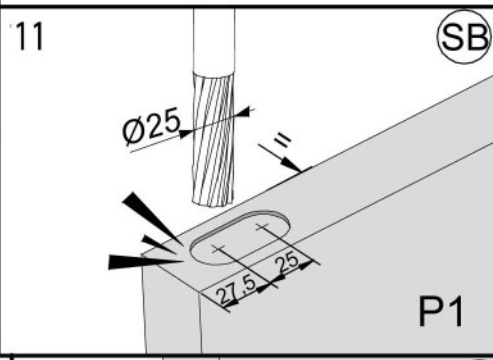
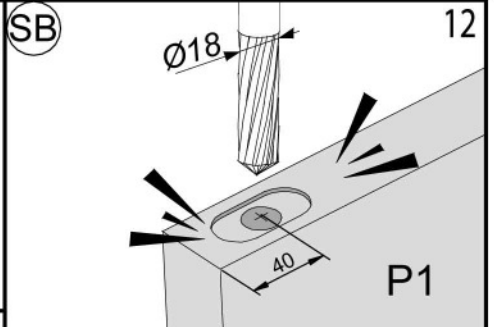
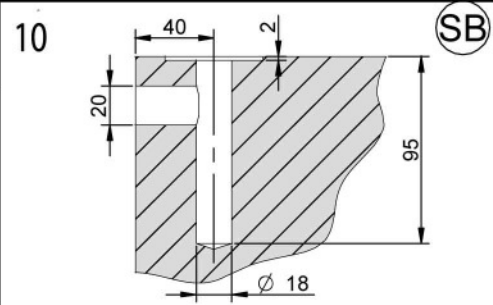
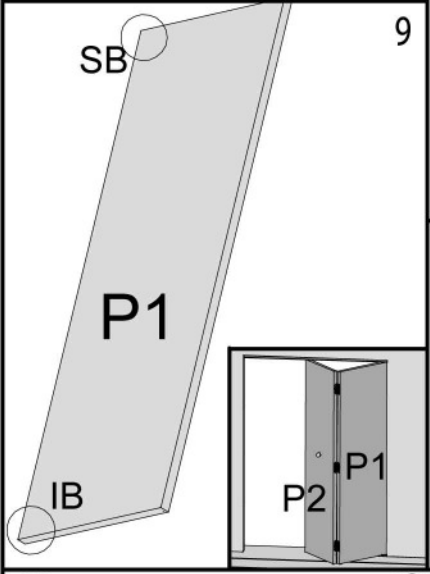

Final door mechanisation

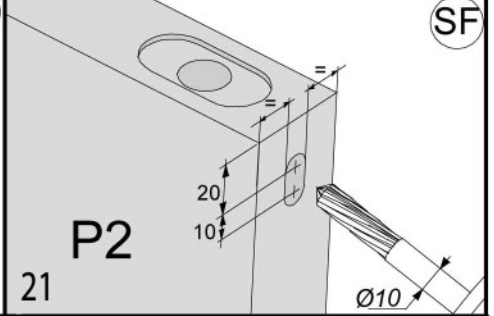
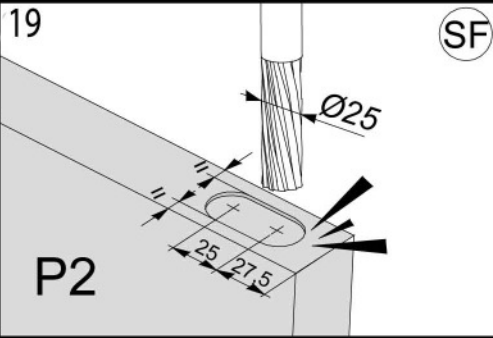
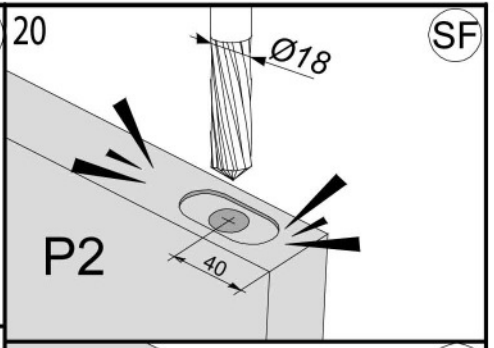
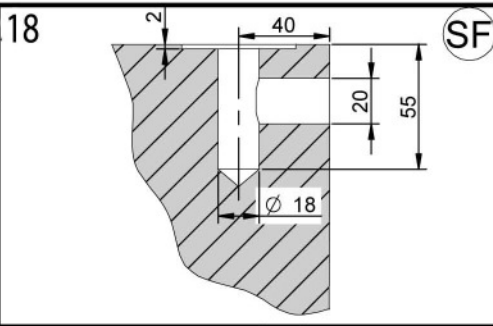
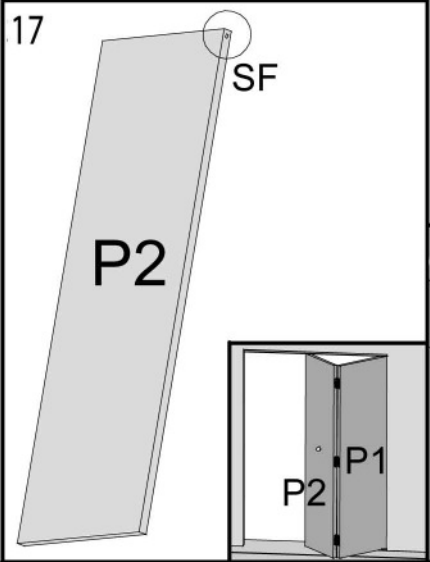

Mechanisation of lower support

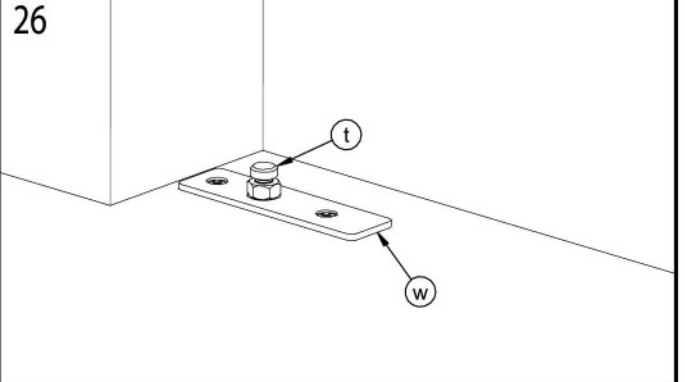
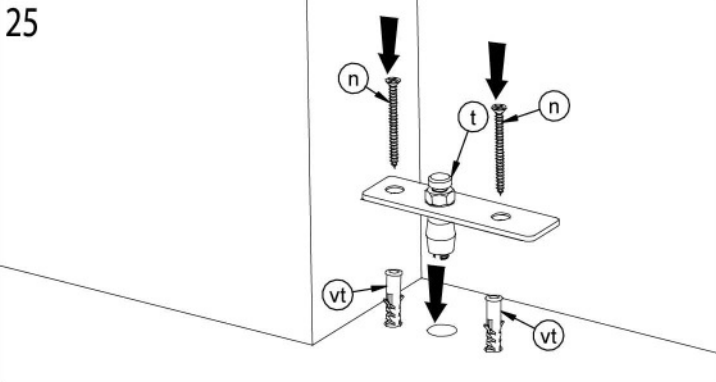
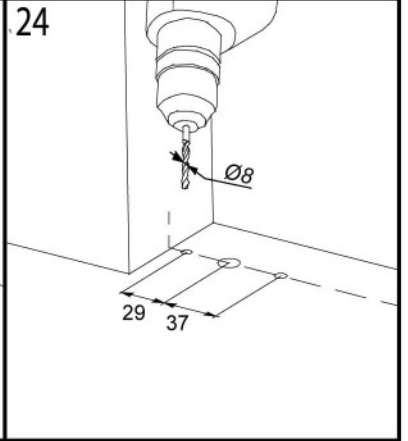
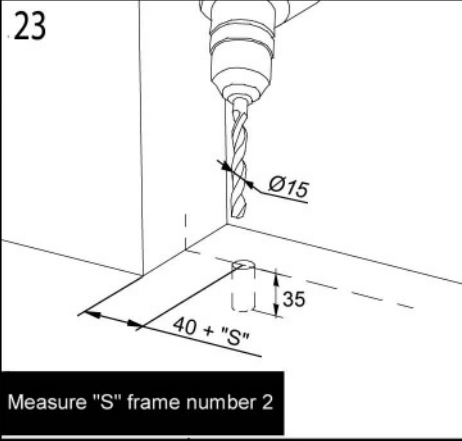
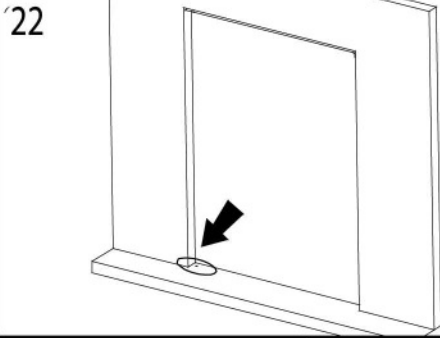

Door assembly

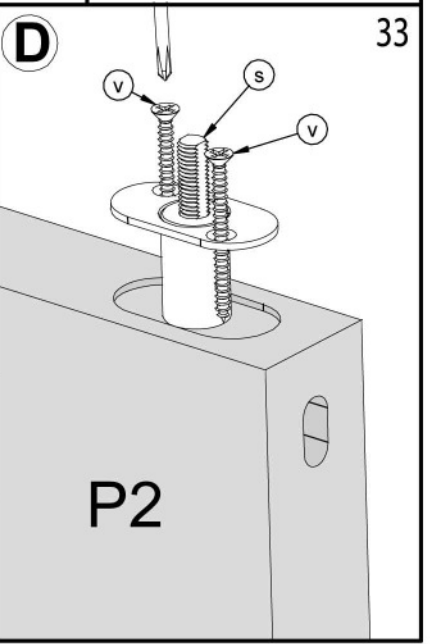
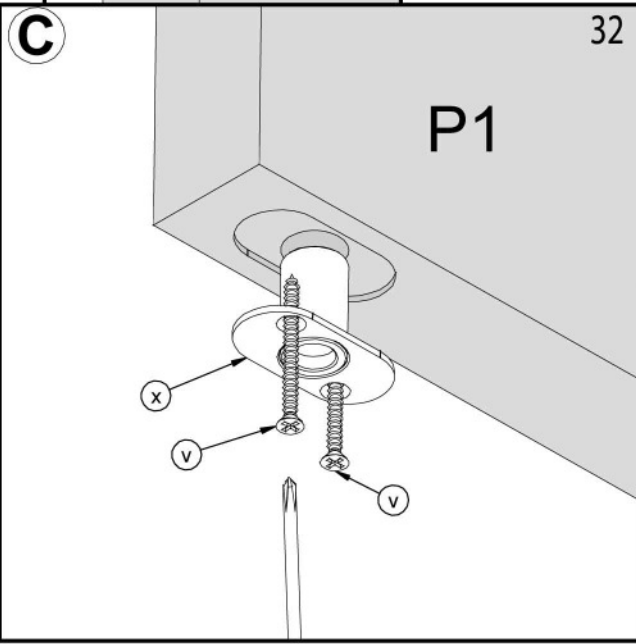
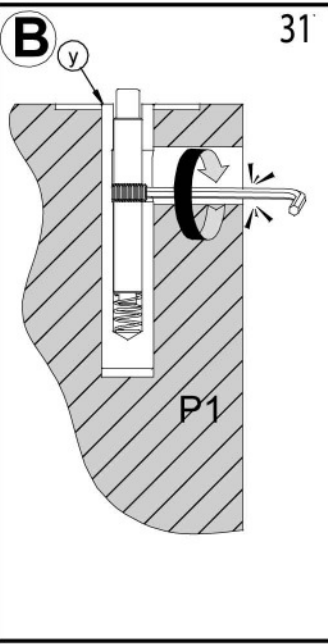
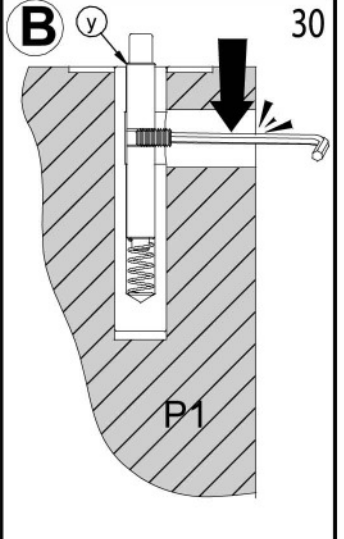
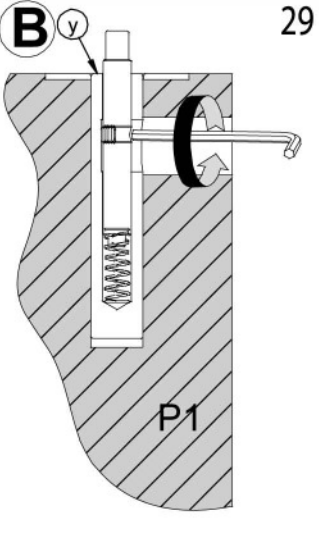
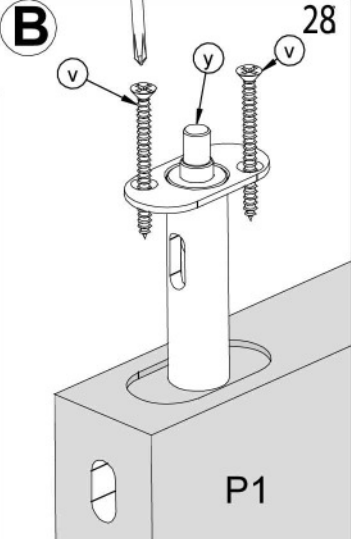
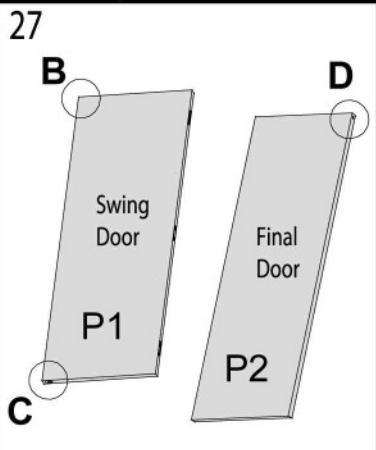

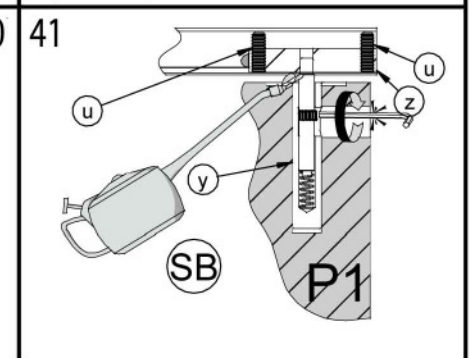
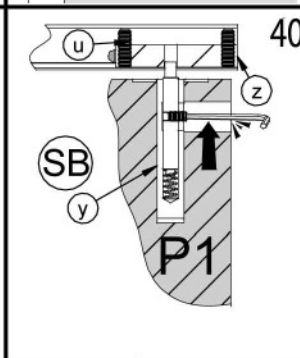
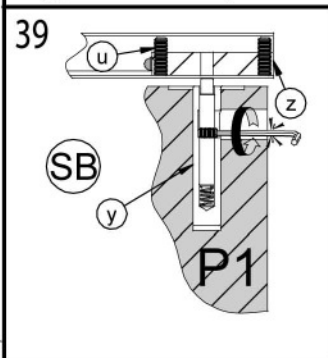
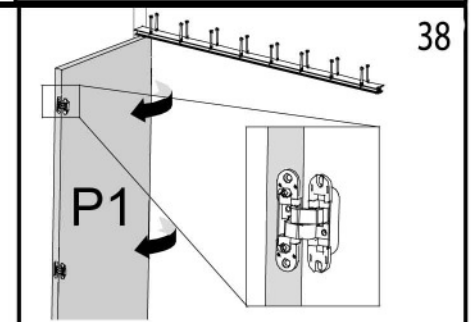
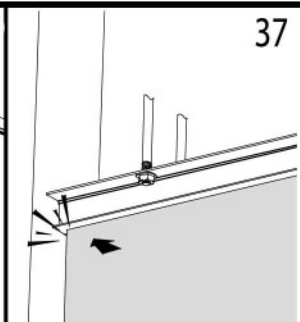
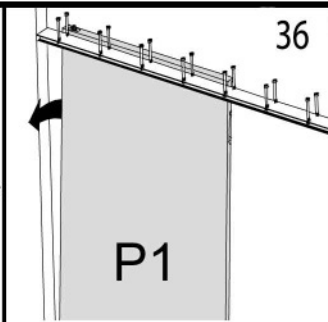
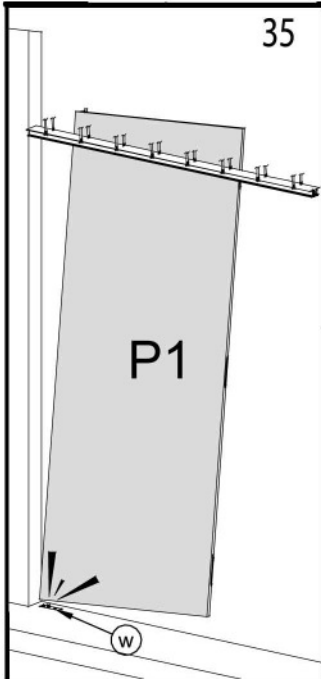
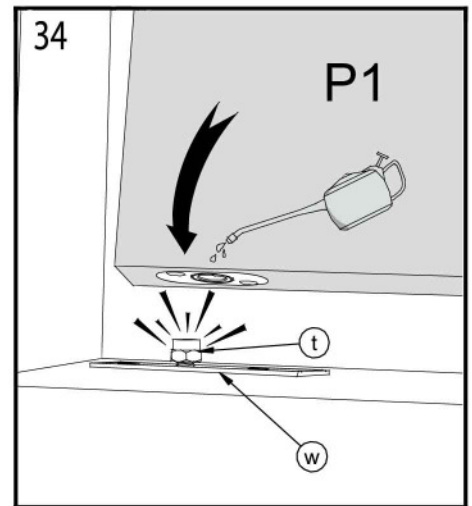

42

Hinge fixing instructions

1. For doors between 35 - 43mm thickness, use H104 HI-LOAD hinges, for doors 44mm+ thickness use H102 HI-LOAD hinges
2. HI-LOAD hinges are fitted similarly to ordinary hinges:-
 - a) Mark out and cut mortice
 - b) Drill pilot holes, sized to suit the fixing screws and the type of frame material being screwed into
 - c) Ensure screws are fully tightened
 - d) No lubrication or maintenance is required

IMPORTANT

HI-LOAD hinges are very accurately manufactured with very little clearance or play. Ensure that hinge halves are accurately fitted both vertically and laterally, and that the axes of the pins are in line. The HI-LOAD hinge should not need painting- if it is to be painted, on no account must paint be allowed onto the bearing surfaces.

The HI-LOAD hinge must not be stoved or heated.

PLEASE NOTE: Bright zinc finish offers both a pleasing aesthetic and robust finish. However, it must be remembered that it is a sacrificial plating and may discolour and tarnish when exposed to adverse conditions, i.e. dampness, salt spray, wet trade pollution and certain cleaning materials.

43

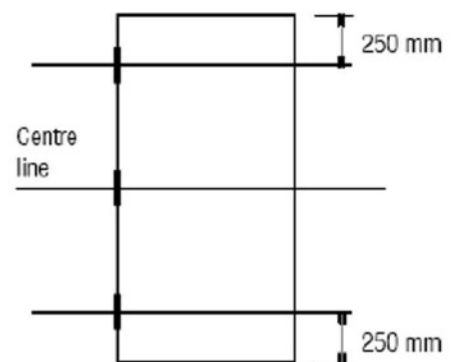

Hinge Positioning

For maximum resistance to warping, position the hinges with equal spacing as above

