

iMpero Double Fire Door Kit

iM820, 821, 823 & 824

FITTING INSTRUCTIONS

PFD30DD Double Fire Door Kit



(Image for reference only)

SUGGESTED TOOLS



DRILL



G-CLAMP



TAPE MEASURE



HACKSAW



PLUMB LINE



HANDSAW



SPIRIT LEVEL



PROTECTIVE EQUIPMENT

COMPONENTS

POCKER DOOR KIT

- SHORT / LONG 'Z' SECTION *
- LONG 'Z' SECTION *
- L-SHAPED TRACK PACKER *
- PLYWOOD TRACK MOUNT *
- ALUMINIUM TRACK *
- DOOR BOTTOM CHANNEL *
- SOLE PLATE *

DOOR JAMB SET

- HEAD SECTION 2
- CASSETTE EDGE JAMB 2
- "T" SHAPED JAMB 1
- PLASTERBOARD PROFILES 6
- INTUMESCENTS 7

SLIDING MECHANISM

- TROLLEY CATCH 2
- TROLLEY ASSEMBLY 2
- FLOOR GUIDE 2

FIXING ITEMS

- END BLOCK 2
- PROTECTIVE EDGE CLIP 2
- CHOCK LARGE 2
- CHOCK SMALL 1
- SET A *
- SET B *
- SET C *
- SET D *
- SET E *
- SET F *

* Quantities are dependant on type of kit ordered

POCKET DOOR KIT

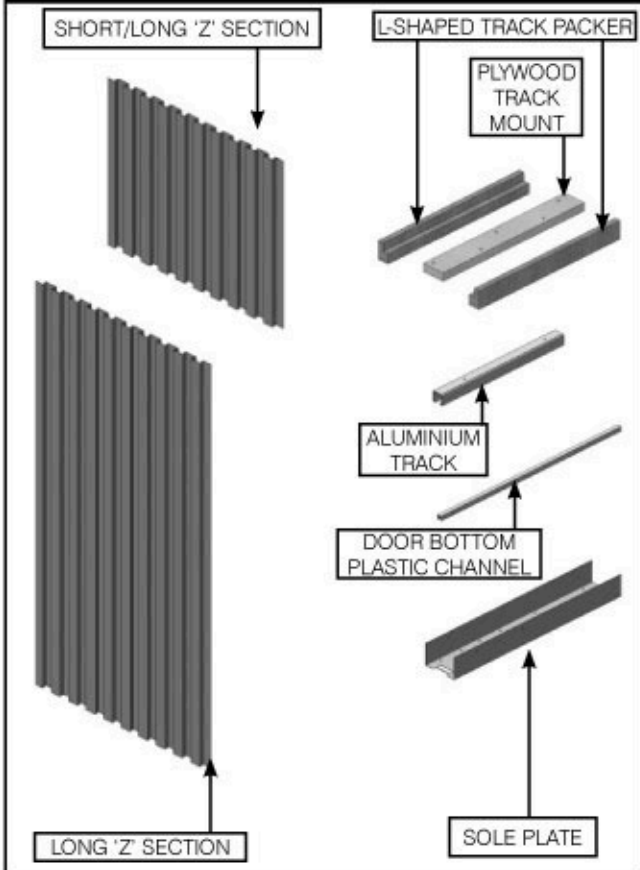

SLIDING MECHANISM

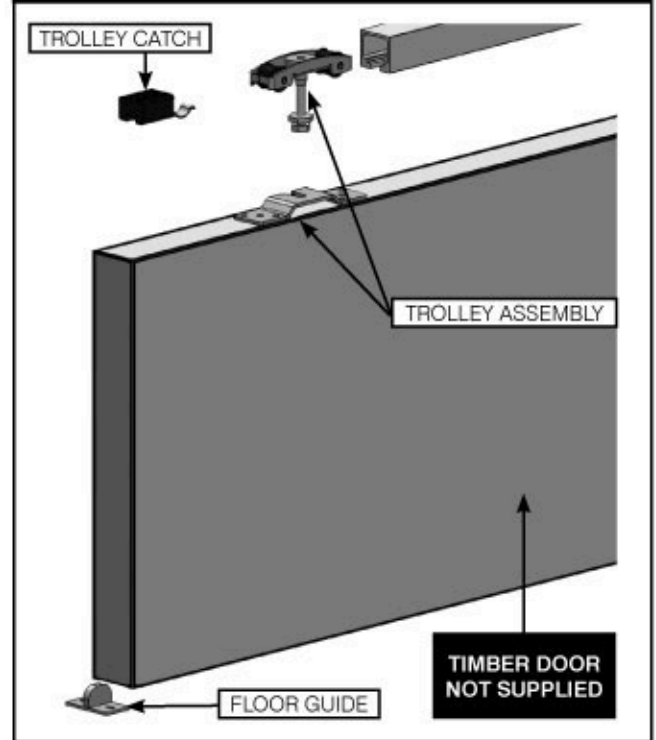

DOOR JAMB SET

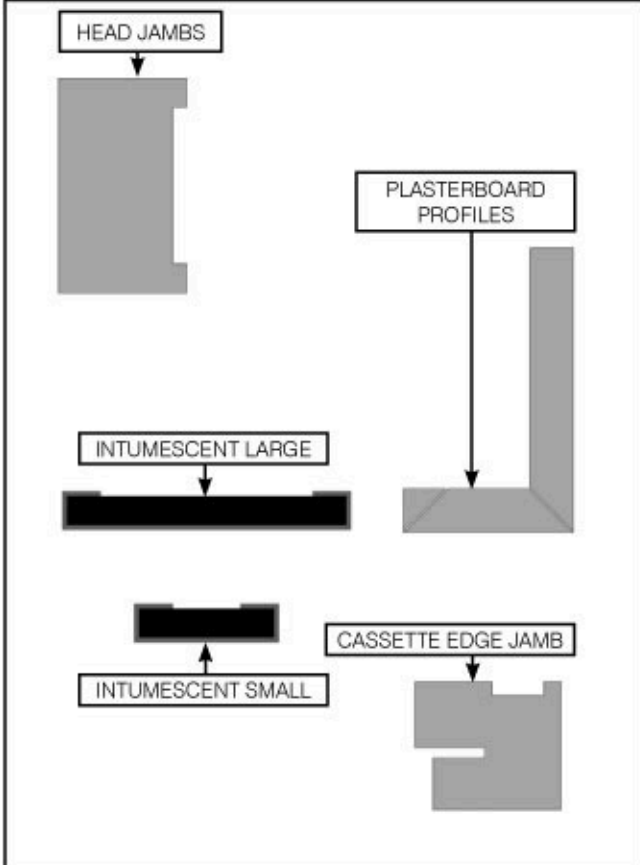

FIXING ITEMS SET

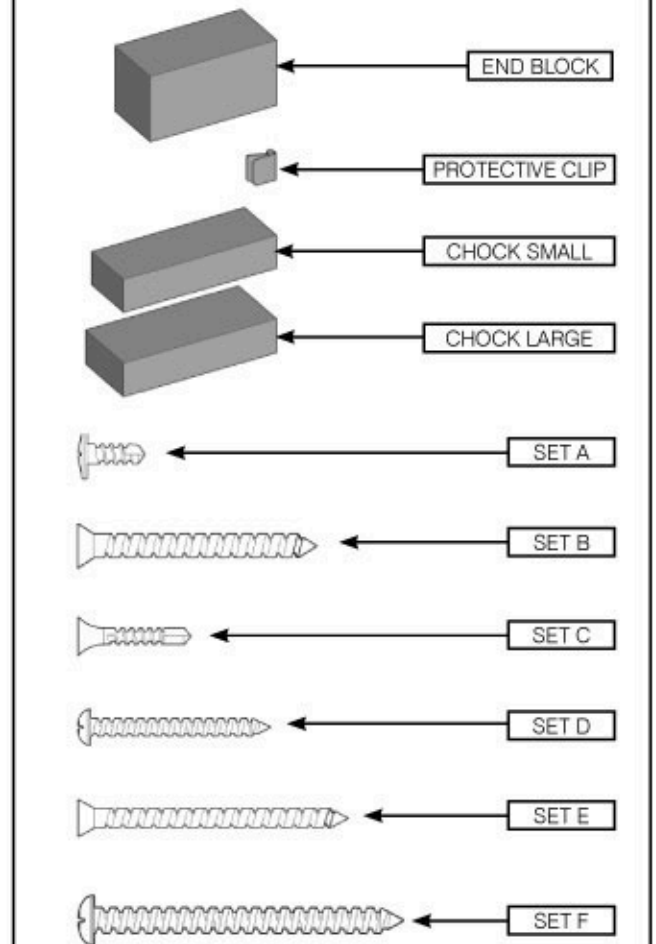

PRE-DOOR FITTING INFORMATION

Firstly construct a studwork frame on which to affix the pocket door system. impero doors are designed with 100mm studwork

For correct operation, it is crucial that the frame is constructed square and plumb.

Abbreviations

W = STUDWORK WIDTH

H = STUDWORK HEIGHT

Op = DOOR OPENING WIDTH

Oh = DOOR OPENING HEIGHT

Wp = COMBINED DOOR WIDTH

Hp = DOOR HEIGHT

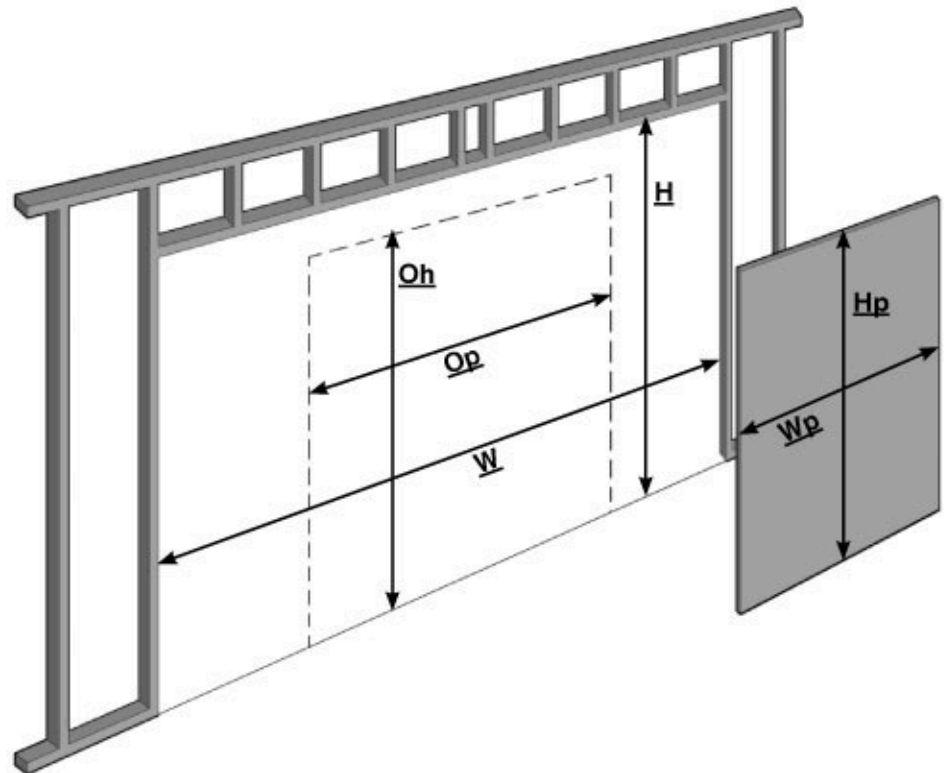

SIZES CAN BE CALCULATED AS FOLLOWS **(FOR SINGLE STANDARD DOOR WITH A DOOR THICKNESS OF 44mm)**

1. To calculate **studwork** width and height from known **door dimensions**:

$$\begin{aligned}\text{Studwork width (W)} &= 4 \times \text{Door width (Wp)} - 80\text{mm} \\ \text{Studwork height (H)} &= \text{Door height (Hp)} + 95\text{mm}\end{aligned}$$

2. To calculate **door size** from known **studwork dimensions**:

$$\begin{aligned}\text{Door width (Wp)} &= (\text{Studwork width (W)} + 80\text{mm}) \div 4 \\ \text{Door height (Hp)} &= \text{Studwork height (H)} - 95\text{mm}\end{aligned}$$

3. To calculate **door size** from known door **opening dimensions**:

$$\begin{aligned}\text{Door width (Wp)} &= (\text{Door opening width (Op)} + 131\text{mm}) \div 2 \\ \text{Door height (Hp)} &= \text{Door opening height (Oh)} + 35\text{mm}\end{aligned}$$

4. To calculate **door opening** width and height from known **door dimensions**:

$$\begin{aligned}\text{Door opening width (Op)} &= (2 \times \text{Door width (Wp)}) - 131\text{mm} \\ \text{Door opening height (Oh)} &= \text{Door height (Hp)} - 35\text{mm}\end{aligned}$$

1. TRACK MOUNT

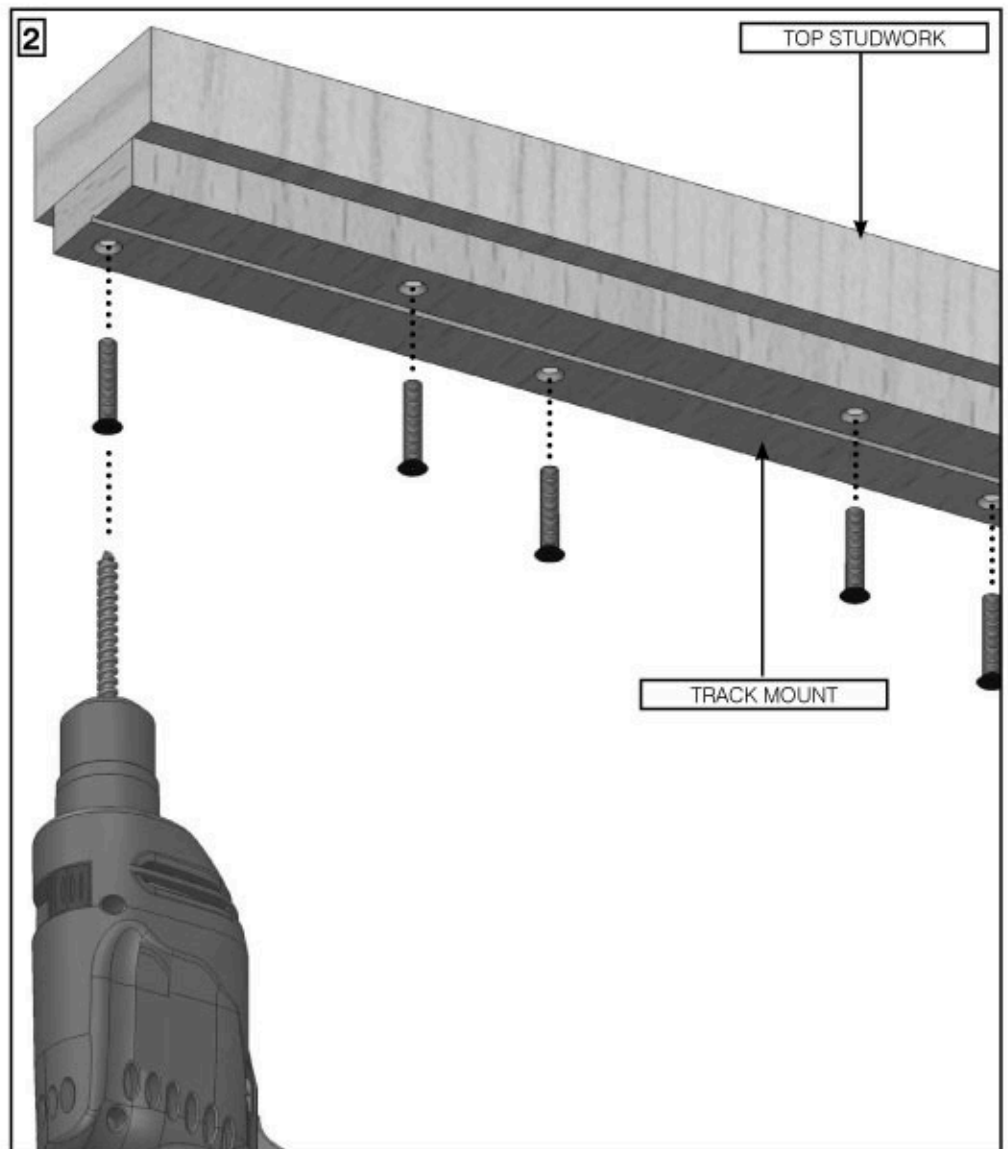
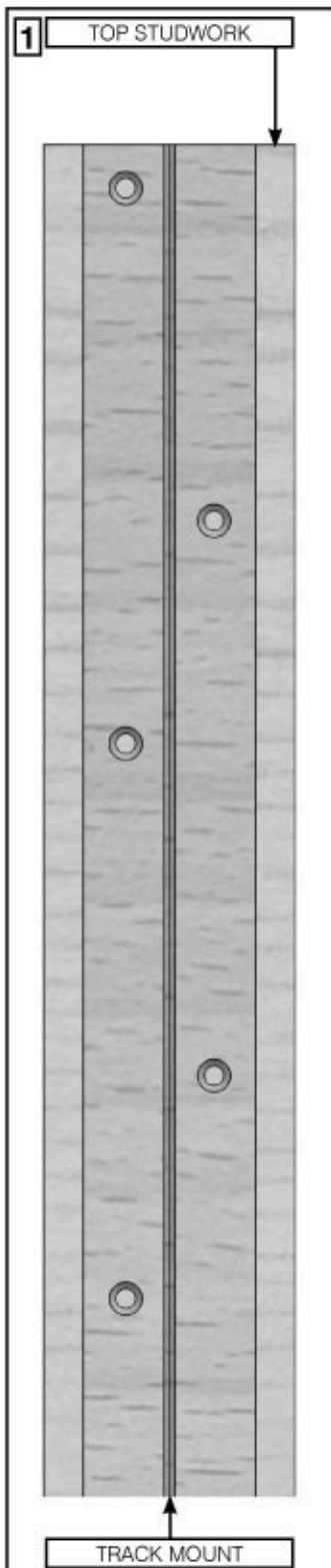

1. Cut the plywood track mount to the width of your horizontal studwork / support frame.
2. Position the track mount in the centre of the top horizontal studwork timber / support frame.
3. Pilot drill and screw through both sides of 'V' Shaped Groove and ensure screw heads are fully sunk into the wood **(Screws not supplied)**.

2. ALUMINIUM TRACK

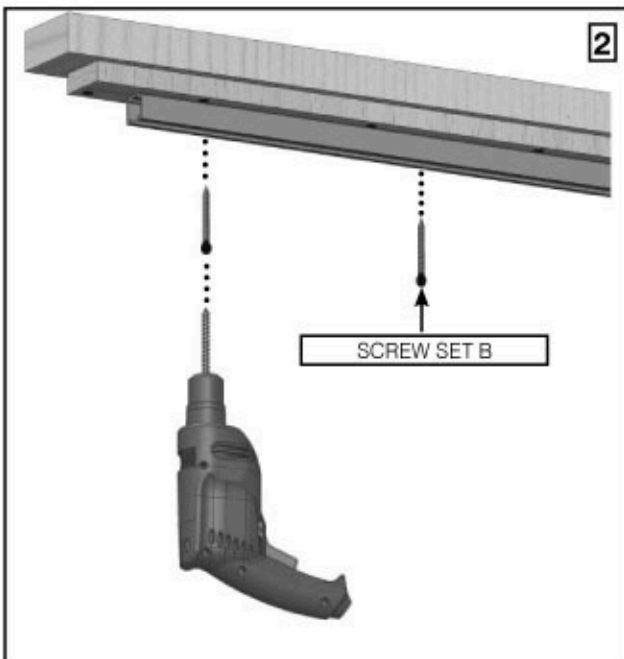
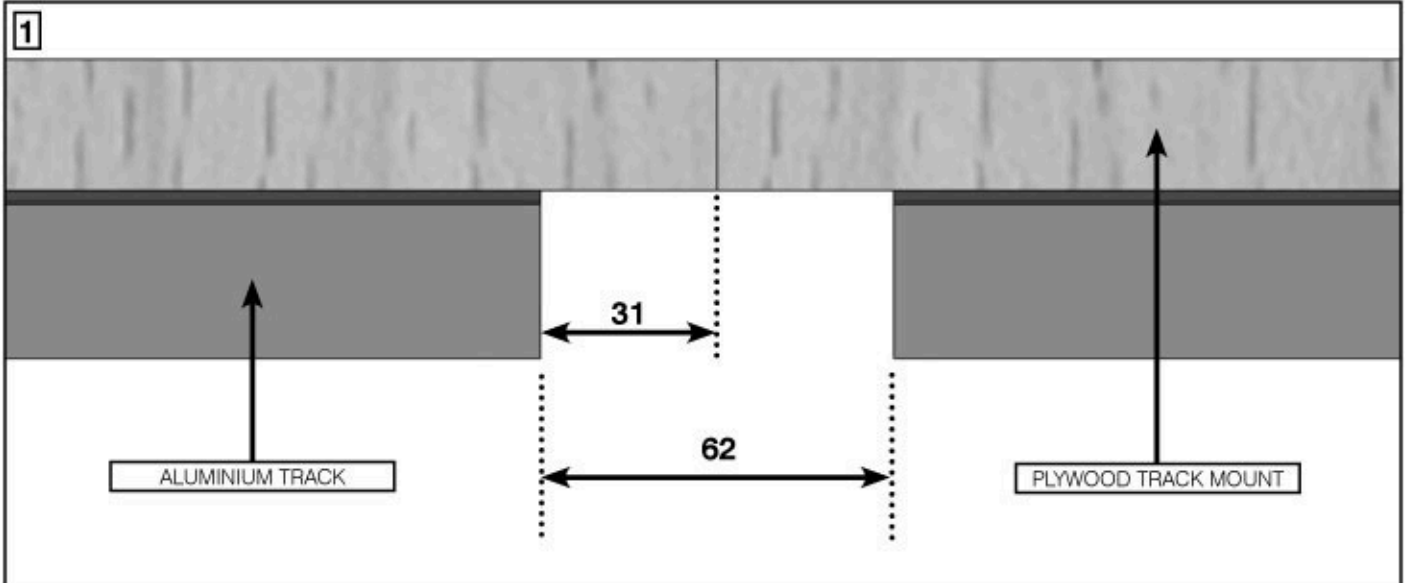

1. Cut the aluminium track to the; $((\text{width of the studwork} \div 2) - 70\text{mm})$.
2. Position tracks 31mm either side of the centre to give a 62mm gap. This will also leave a 39mm gap at the back of the rail which will be used to fit the trolley catches.

Pilot drill through the holes in the track into the 'V' Shaped groove in the plywood track mount. Screwfix using '**Screw Set B**'.

TRACK SHOULD BE WIPED CLEAN TO REMOVE ANY CONTAMINANT

3. SOLE PLATE

1. Position the leading edge of the sole plate (Door panel width minus 9mm) away from the inside face of the rear studwork.

Sole Plate may need cutting down depending on door size.

2. Butt the sole plate centrally to the studwork at the back edge of the pocket.
3. Plumb true to the aluminium track above and secure the plate to the floor with appropriate fixings (**not supplied**).

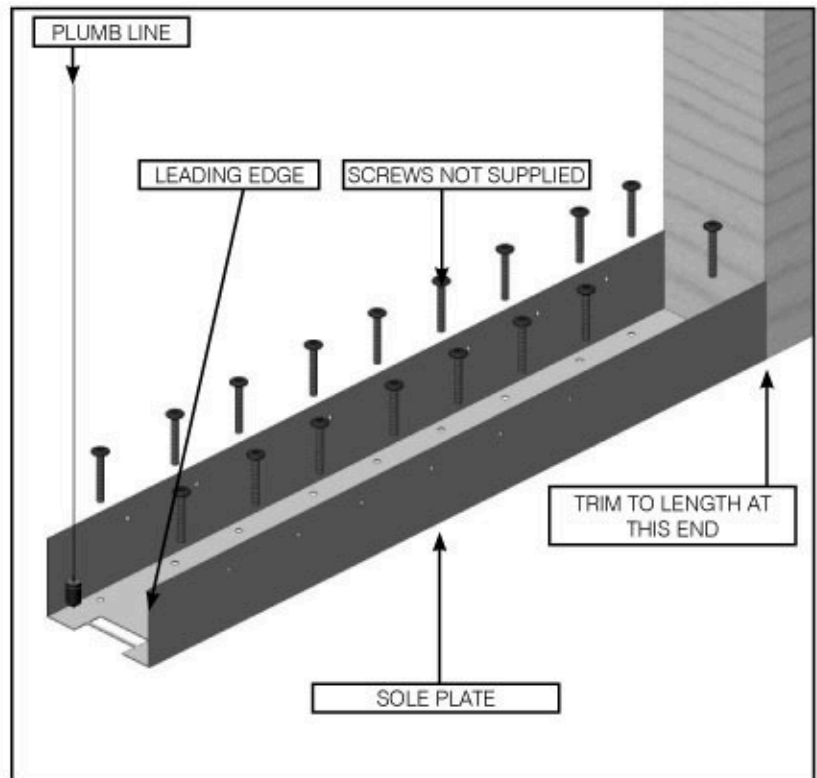

4. 'Z' PANELS

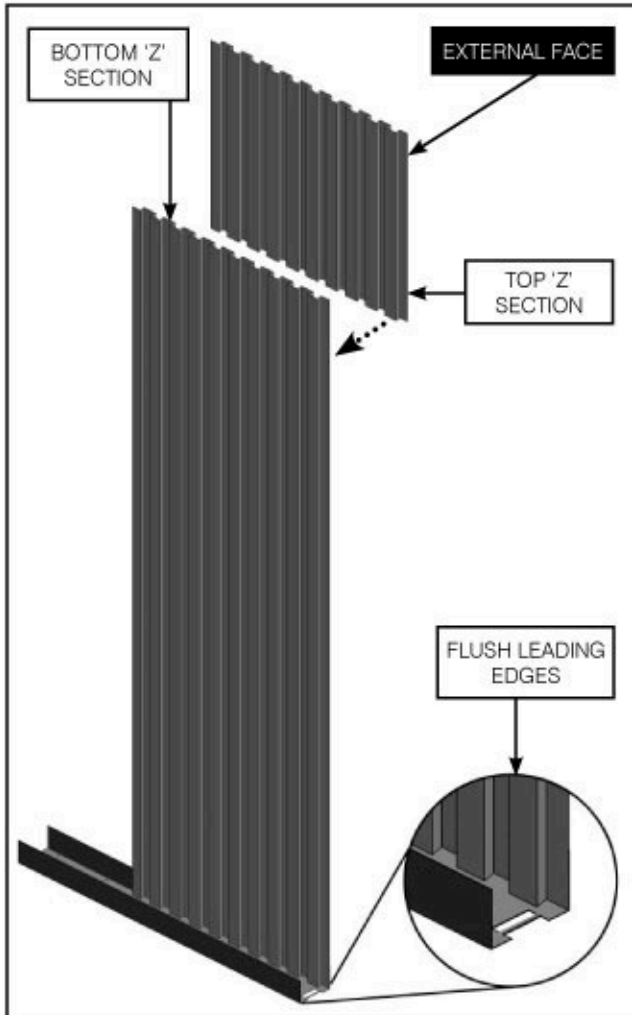

1. Adjust the 'Z' Panels to desired height (inside surface of sole plate to underside of top studwork).
2. Position the bottom 'Z' Panel inside the sole plate so that both leading edges are flush.

Make sure the top 'Z' section is on the outside of the pocket.

Please Note: With wide and intermediary kits a second set of metal 'Z' panels are supplied. The second set should be installed level with the rear of the sole plate. On the intermediary kits the narrow sheets should be to the rear of the pocket

IF YOU ARE USING A REINFORCING KIT - PLEASE REFER TO INSTRUCTIONS 003-285 AND INSTALL IT AT THIS POINT BEFORE SCREW FIXING THE 'Z' PANELS

PLEASE NOTE: TOP 'Z' SECTION IS ON THE OUTSIDE OF THE POCKET

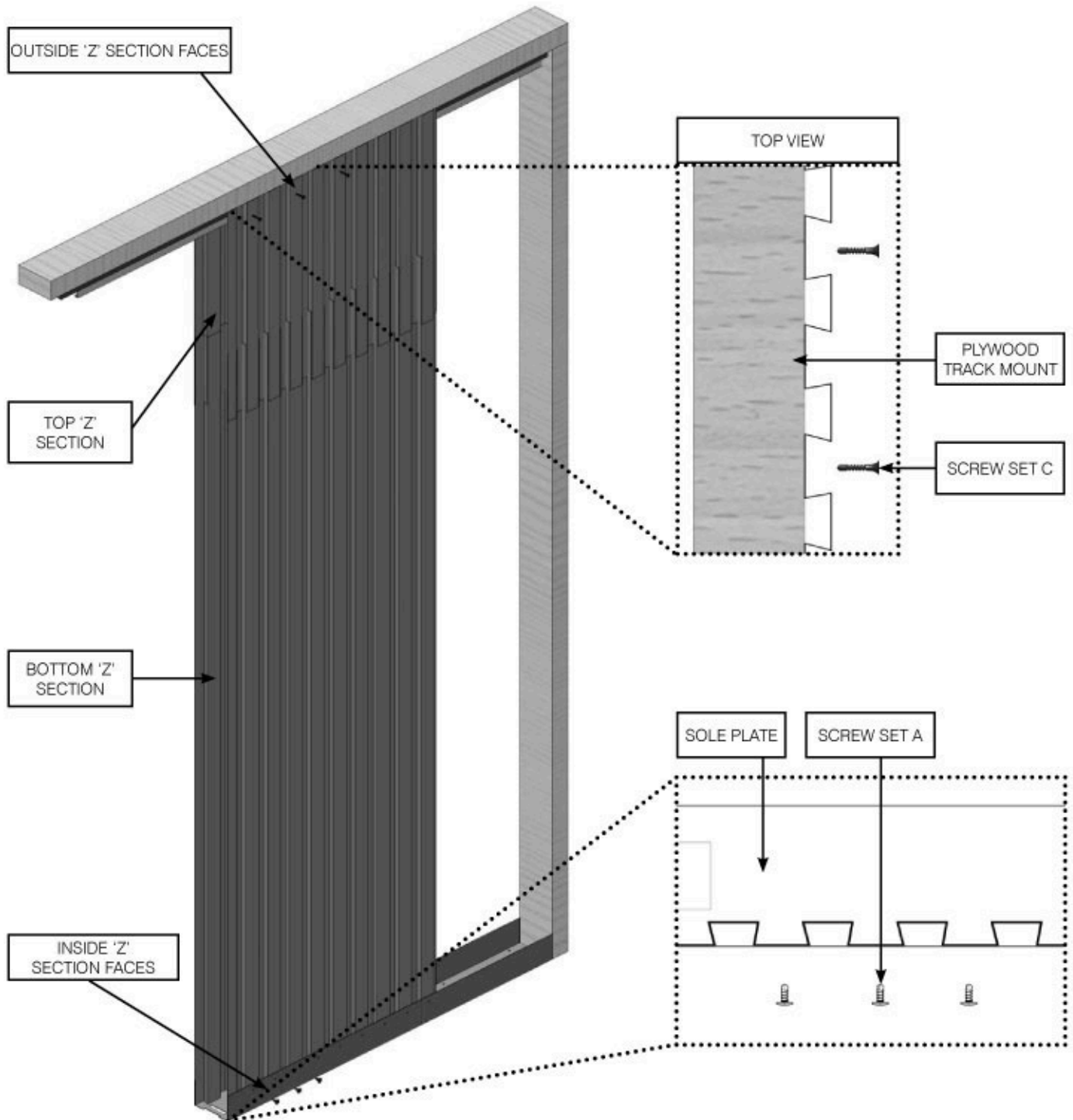

Ensure panels are level and then fix with screws.

1. Fix top 'Z' Section to plywood track mount with '**Screw Set C**'.
2. Fix bottom 'Z' section to sole plate with '**Screw Set A**'.

5. PANEL JOINING

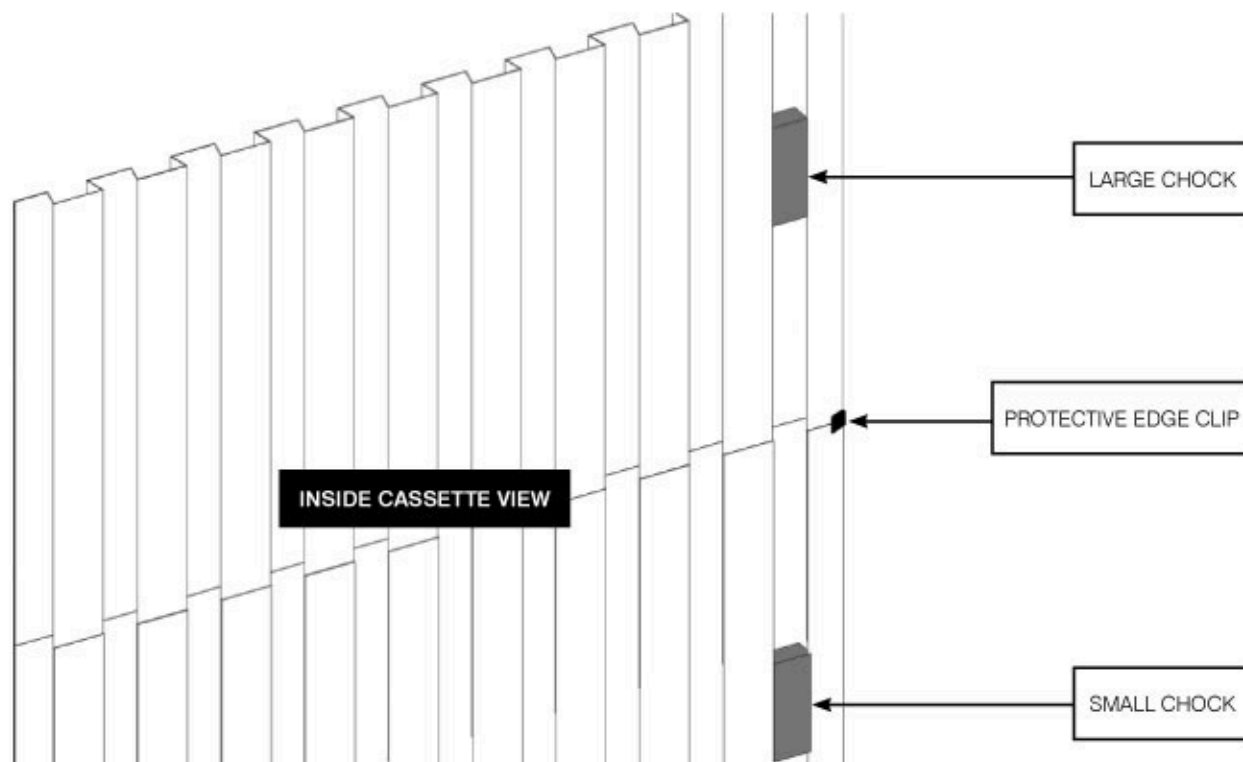

At the back of the pocket, place the protective edge clip onto the 'Z' section, covering where the panels join.

In the last 'Z' section slot towards the back of the inside pocket, push the large chock into the top 'Z' section and the two small chocks into the bottom 'Z' section.

This pushes the edge outwards so the door does not snag on it when closing.

For intermediary and wide kits, fit the chocks in the first and last slot in the rear 'Z' sections as detailed above. Fit protective edge clips to all joints on rear panels.

Repeat stages 3 - 5 on the other side of the pocket.

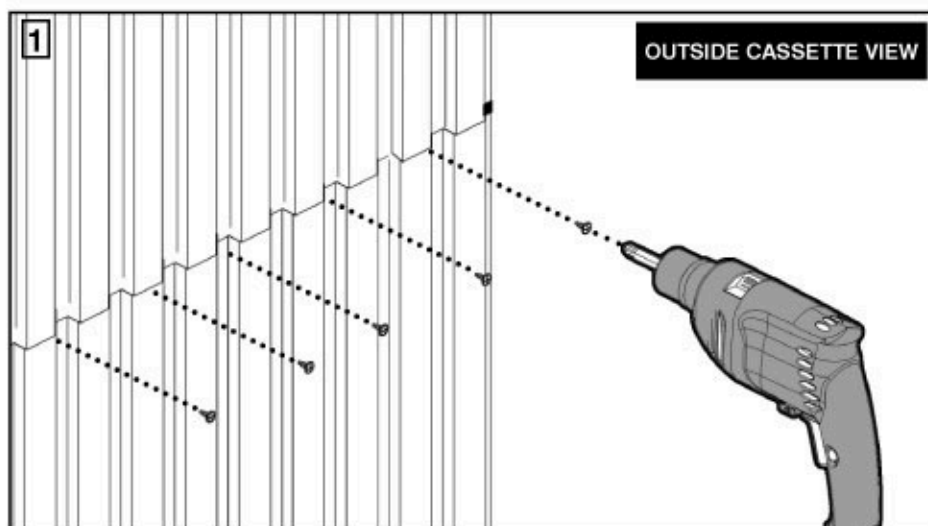

1. Screw through from outside to join panels together in five locations using **'Screw Set A'** (pilot holes not required).

ENSURE WHEN SCREWING THE TWO SHEETS THEY ARE STRAIGHT AND DO NOT BECOME BOWED AS THE SCREW PUSHES THROUGH

6. TROLLEY MOUNTING

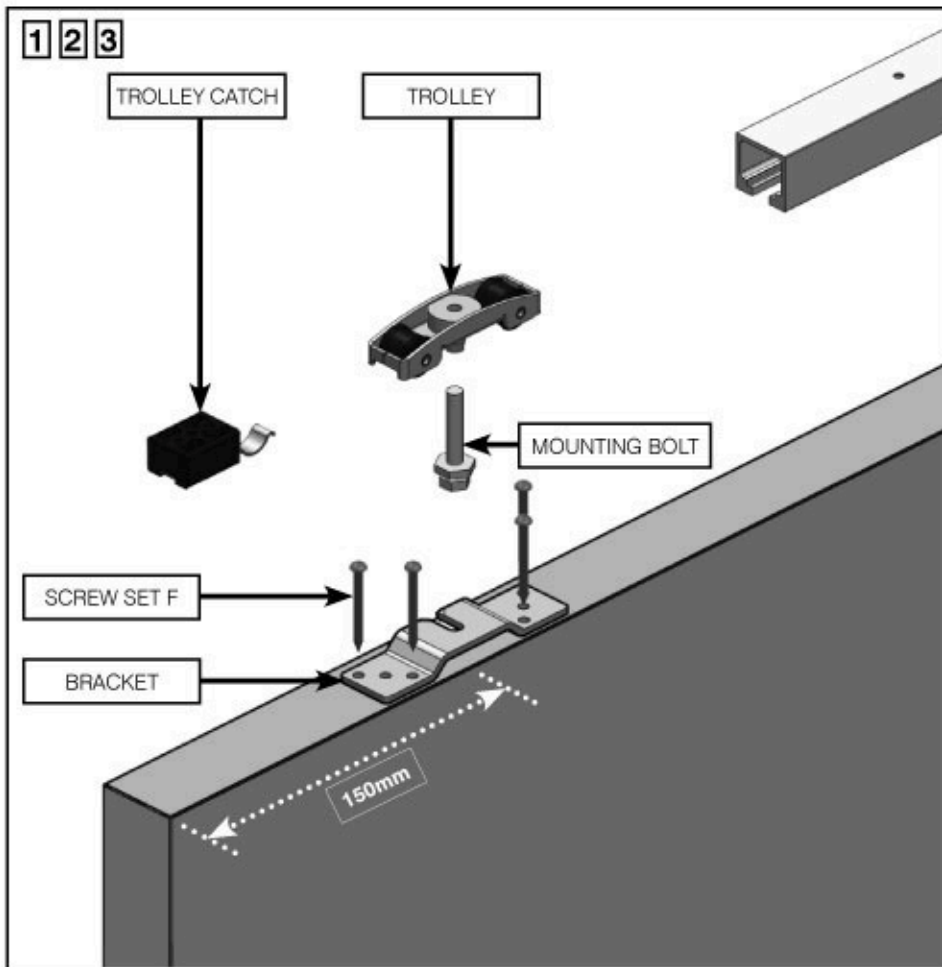

IF USING A TOUCH LATCH SYSTEM - DISCARD REAR TROLLEY CATCHES

1. Fit the bracket centrally to the top edge of the door using **'Screw Set F'**. Ensure the brackets centre is 150mm away from the door edge. Repeat the procedure for the other bracket.
2. Screw the mounting bolts into the trolleys. Ensure both bolts are screwed in the same amount on both trolleys to ensure the door is level and make adjustment easier.
3. Slide both assembled trolleys into the top rail.
4. Slide both trolley catches into the track, one at the front and one at the back. Do not fix them in place until the door has been hung (This is explained in Stage 11 of the instructions)

7. DOOR GUIDE

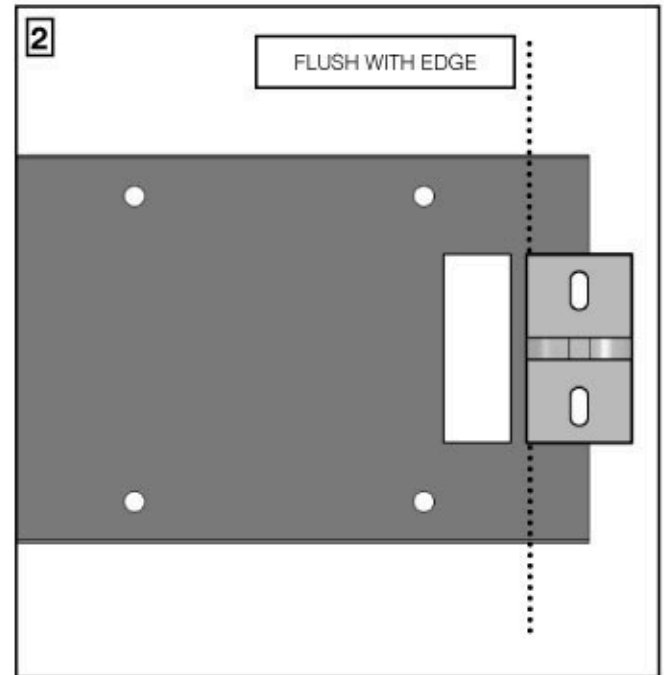
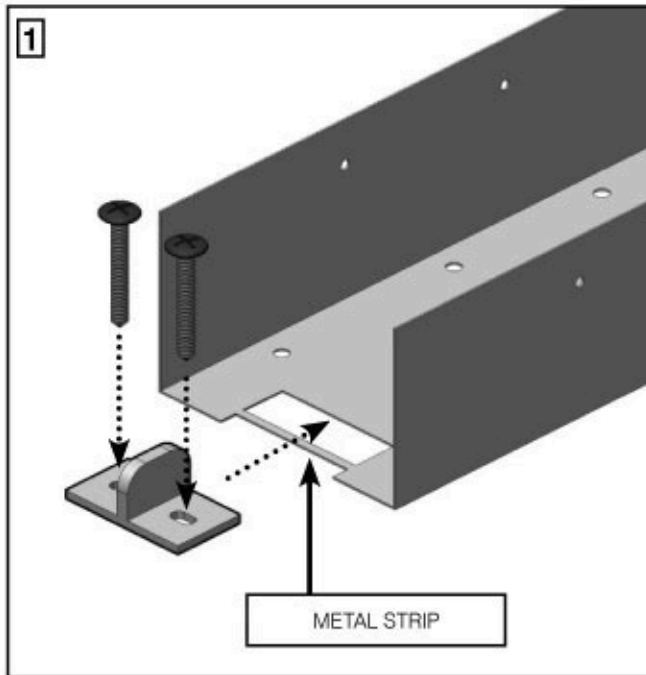

1. Fix the metal floor guide into the sole plate by inserting it into the pre-cut area.
2. Ensure it is flush with the leading edge of the metal strip and sits proud of the front of the sole plate. Scew fix firmly into the floor. **(screws not included).**

8. BOTTOM DOOR GROOVE

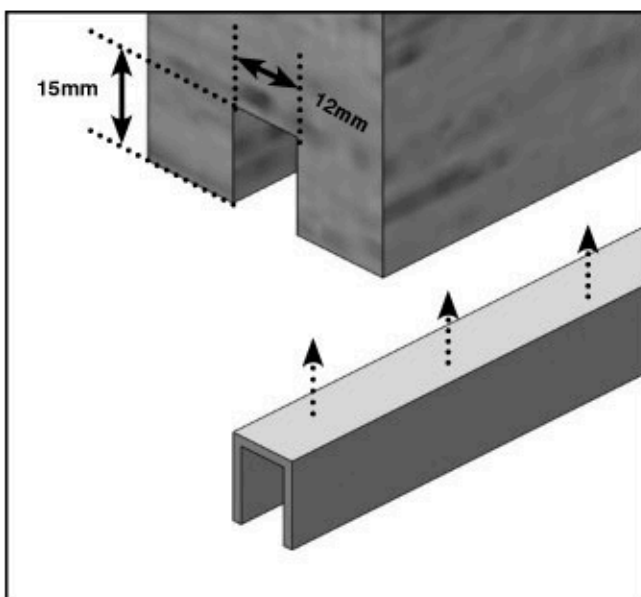

1. Cut a groove in the bottom face of the door to suit the plastic channel which the floor guide runs in.

Ensure when cutting the groove it is centralised along the width of the door.
2. Bond the channel into the cut groove using a polyurethane glue or pin, ensuring the metal floor guide can move freely within it.

9. INTUMESCENT FITTING

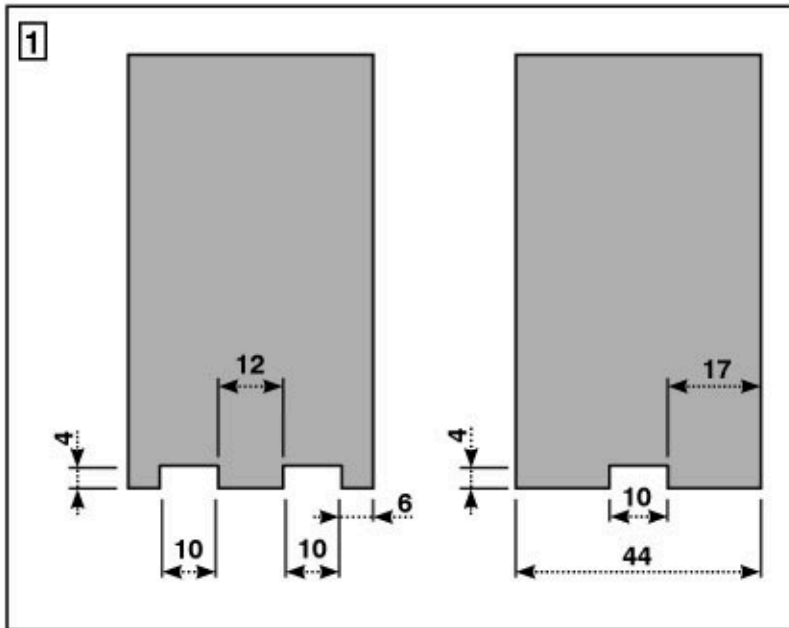

1. Both doors require the fitting of 10 x 4mm intumescent on the meeting style edge.

One door requires 2 lengths of intumescent - the other only requires one.

Details of the cut outs required can be found on the drawing opposite.

PLEASE NOTE THE CUT OUTS NEED TO RUN THE FULL HEIGHT OF THE DOOR.

10. DOOR HANGING

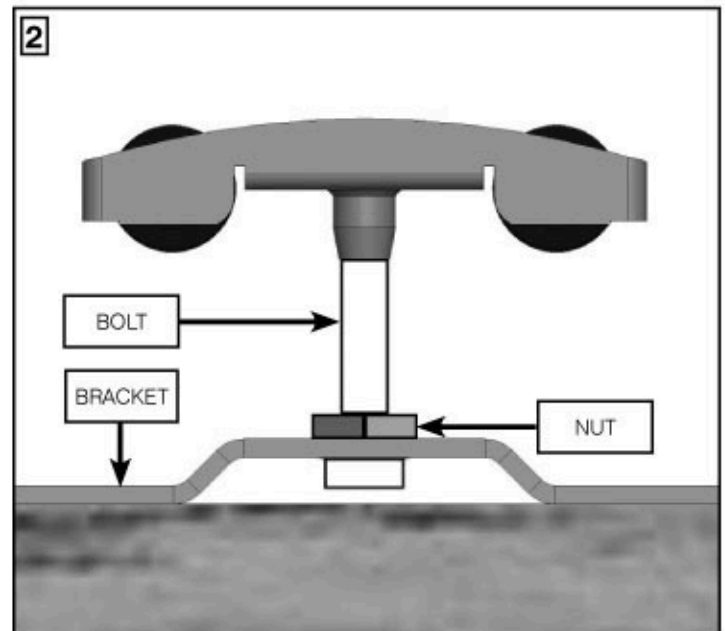
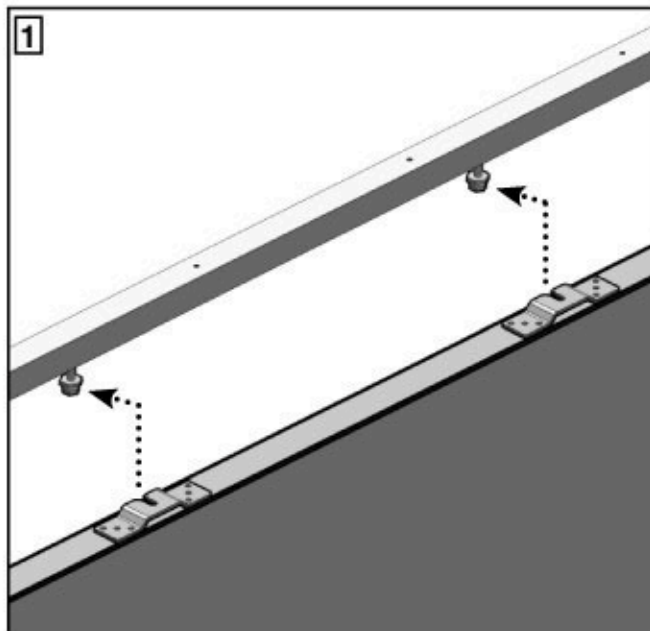

1. Hang the door by sliding the brackets onto the bolts, taking care not to damage the door on the floor guide.
2. Tighten the top nuts onto the brackets to fix the trolleys into place.

TEST TO SEE IF THE DOOR RUNS SMOOTHLY AND IS PLUMB

IF NOT, CORRECT BY ADJUSTING THE NUTS AND BOLTS

11. TROLLEY FIXING

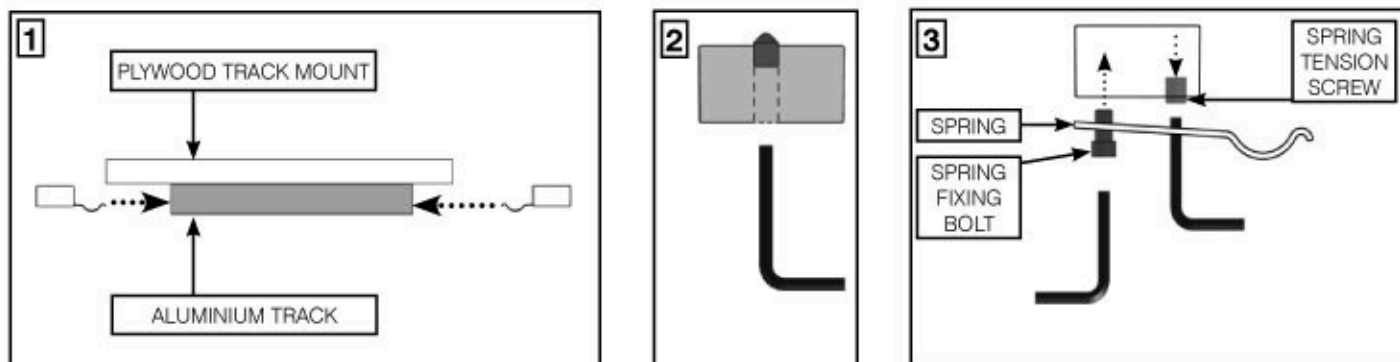

1. Place trolley catches in front and back of aluminium track.
2. Fix trolley catches in required positions within the aluminium track by removing the spring giving access to the centre hole locking grub screw. A 3mm allen key is required.
3. Replace the spring and adjust the clamping bolt to the desired tension to hold the trolleys in place using an M5 allen key.

12. JAMB FITTING - CASSETTE JAMBS

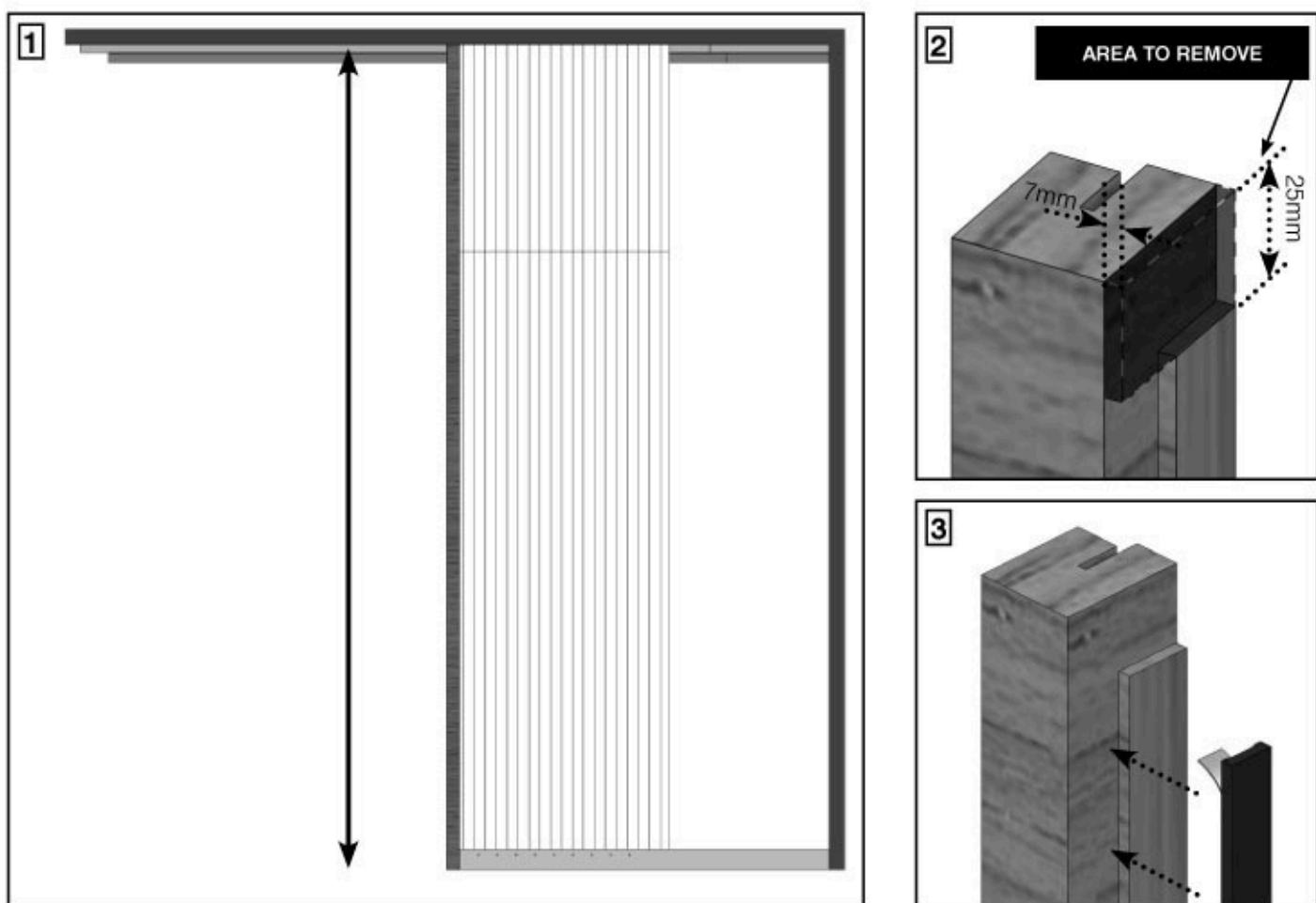

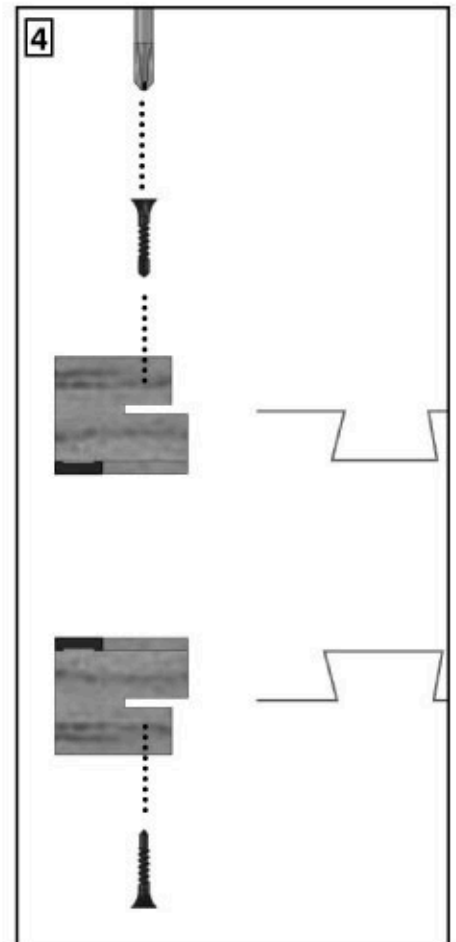
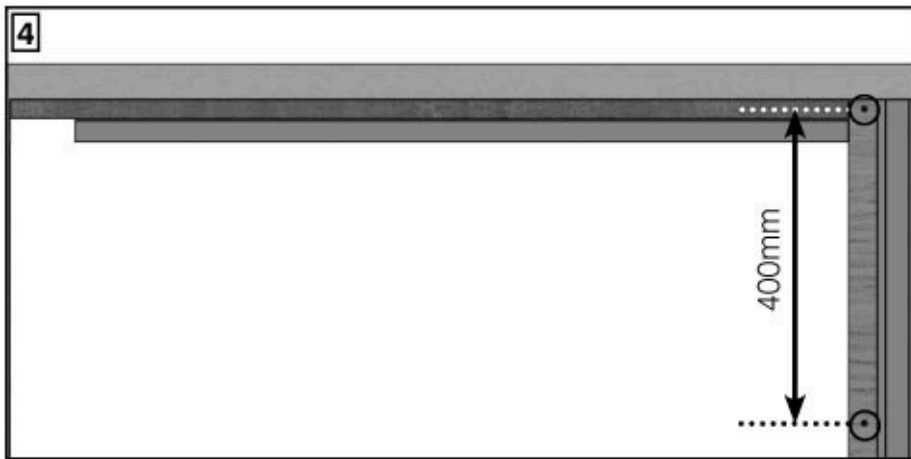

1. Cut the cassette jambs to the aperture height from floor to underside of stud.
2. Using a cutting or sawing tool cut a notch at the top of both jambs that is 25mm down and 7mm deep.
3. Install 15mm x 4mm intumescent strips using their self adhesive backing into the preformed slots in the jambs.
4. Press the jambs onto the edge of the 'Z' Sections and secure with **'Screw Set C'**. Screw at the top and bottom and then approximately every 400mm.

13. 'L' SHAPED TRACK PACKERS

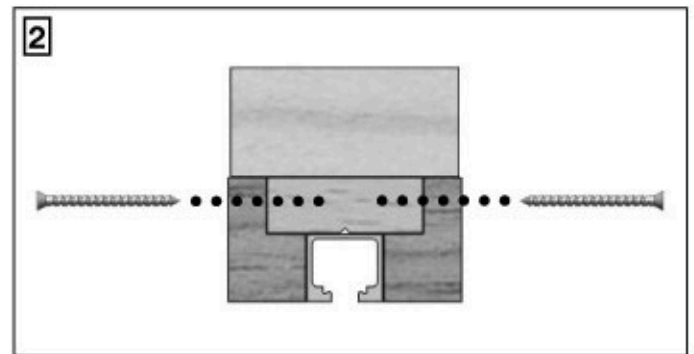
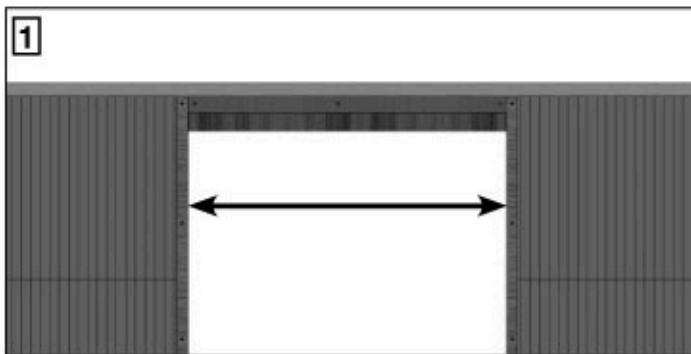

1. To cut the 'L' Shaped track packers, measure remaining door opening width. If the remaining door width is over 2000mm, two packers will need to be butt jointed either side.
2. To secure the 'L' shaped packers, first pilot and countersink a series of holes in their length, approximately 300mm apart. Screw surely through into the plywood track mount using **'Screw Set E'**.

14. JAMB FITTING - HEAD JAMB

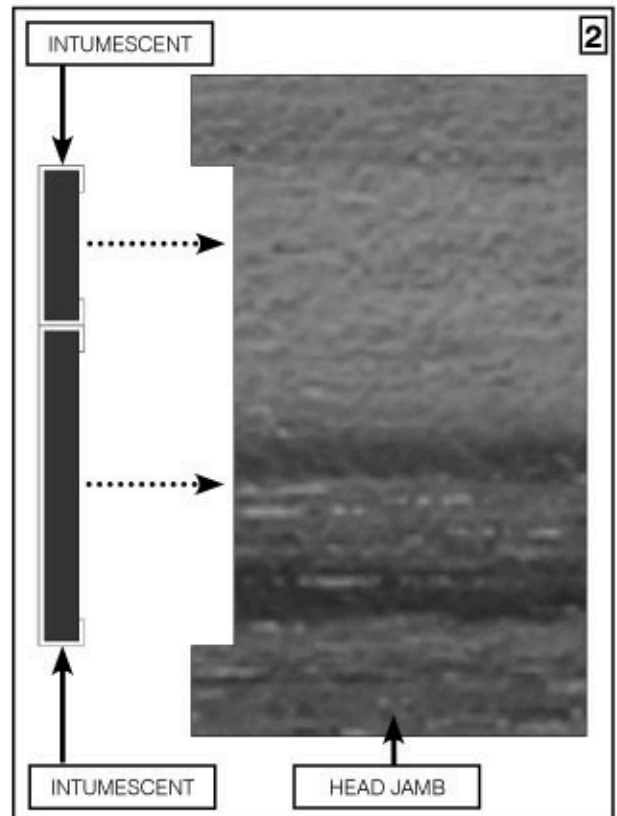
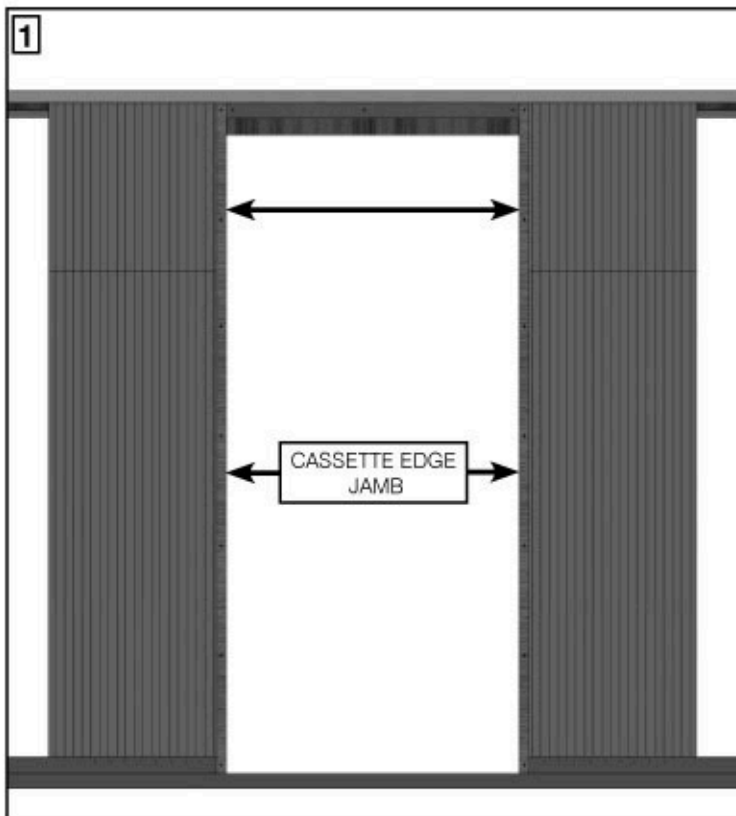

1. Cut the head jamps to fit between both cassette jamb leading edges. Two may need to be used butted up against each other depending on your door widths.
2. Install 30mm x 4mm and 15mm x 4mm intumescent strips using their self adhesive backing into the preformed slots in the head sections.
3. An 80mm woodscrew is used to screw through the head section fixing into the L-Shaped Track Packer, the screws being approximately 300mm apart along the head sections length.

Screws are not supplied

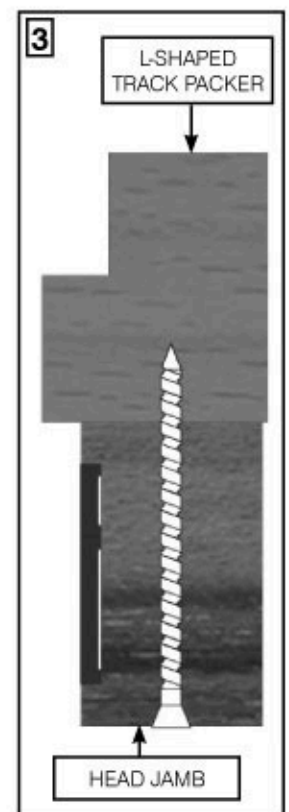

15. END BLOCK

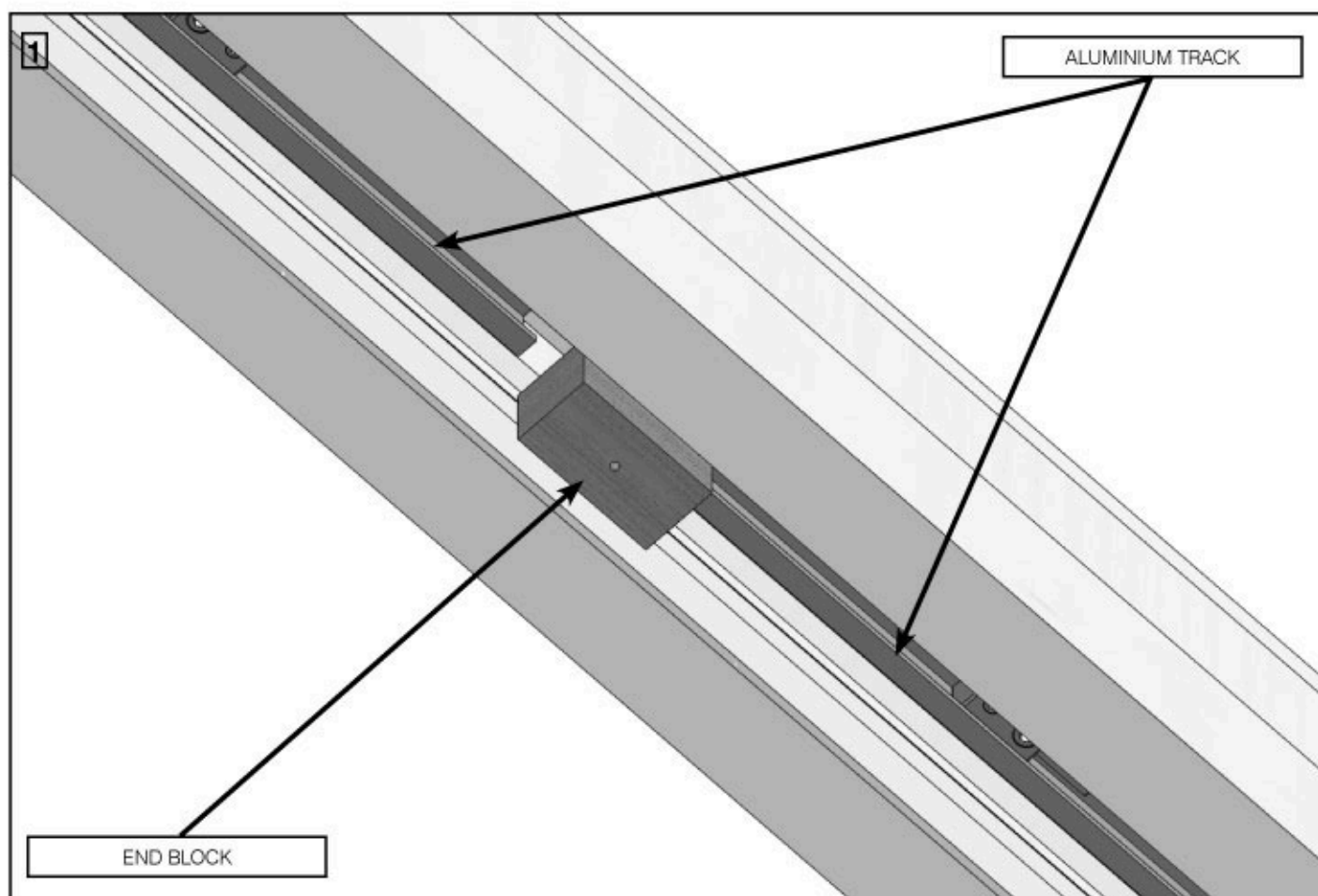

1. Screw the end block through the pre-made hole with '**Screw Set D**' into the 62mm spacing left between the aluminium tracks.

16. PLASTERBOARD

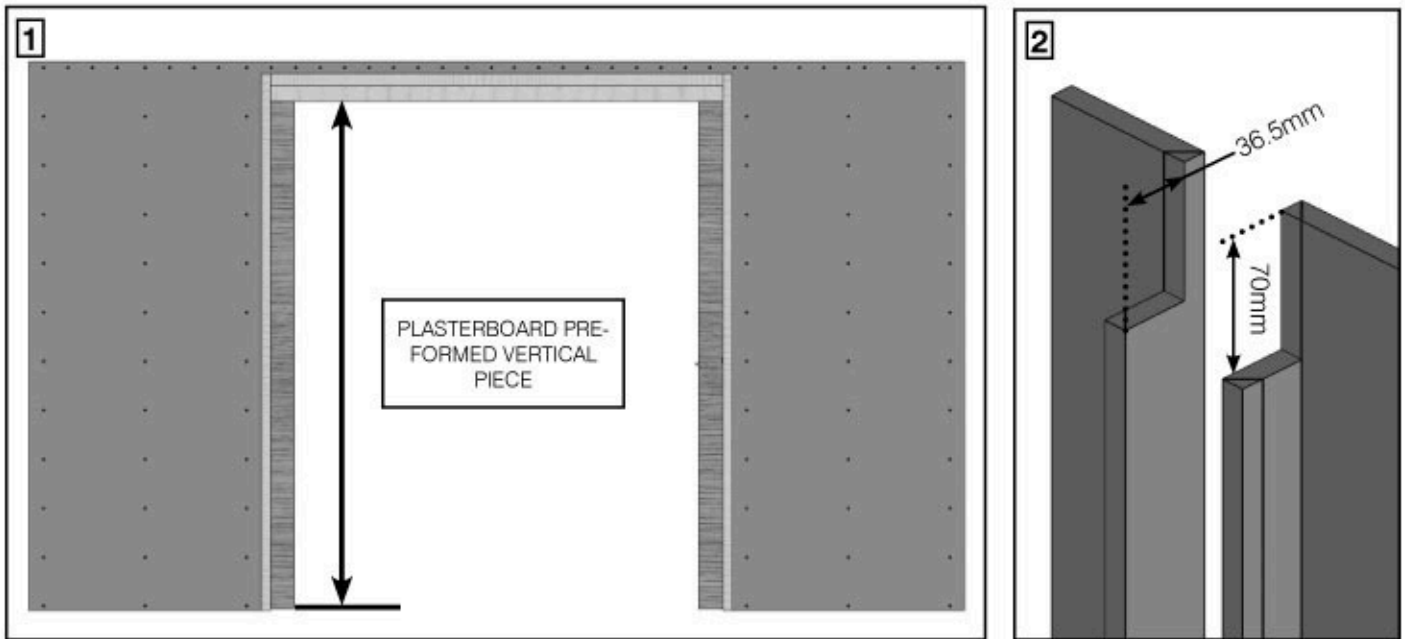

1. Clad the kit in the first layer of 12.5mm thick plasterboard. Ensure it butts up tight against the outside of all jambs.
2. Measure from the floor to the under side of the head jamb and add 70mm. Using this measurement cut the provided vertical plasterboard profiles.

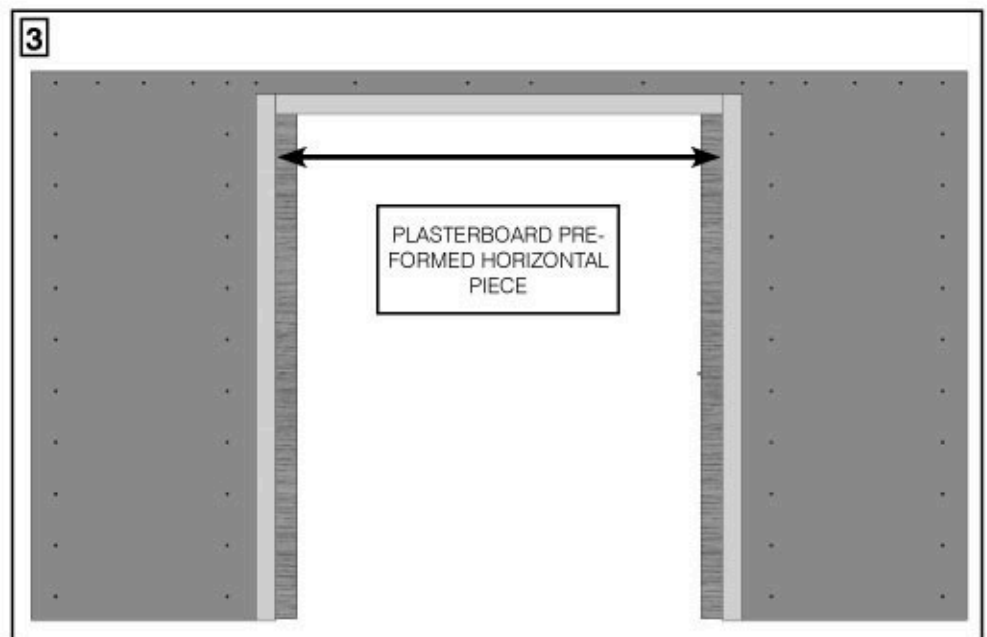

3. Cut both left and right vertical profiles as pictured removing 70mm of material. and install on cassette jamb edges. This cut will be at the top of each profile.
4. Measure from the inside edges of both vertical plasterboard profiles and cut the horizontal profile to this length and install.
5. Clad the kit in a final layer of plasterboard, butting the sheets up to the pre-formed sections

Take care that any screws do not protrude into the pocket cavity

FIXINGS FOR THIS STAGE ARE NOT SUPPLIED